

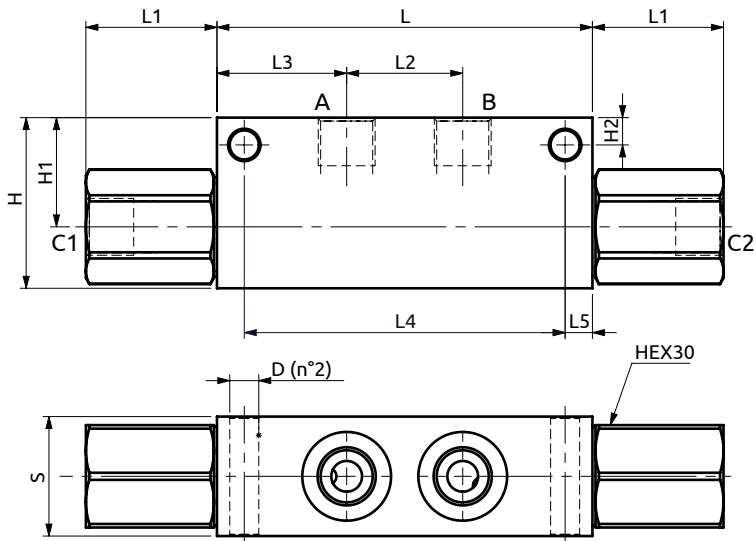

Valvola di blocco doppia pilotata
Dual pilot operated check valve

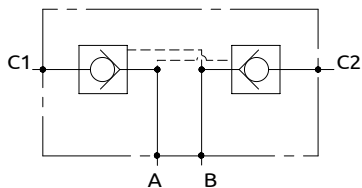

PRESSIONE / PRESSURE - Δp (bar)

CURVE CARATTERISTICHE
PERFORMANCE CURVES

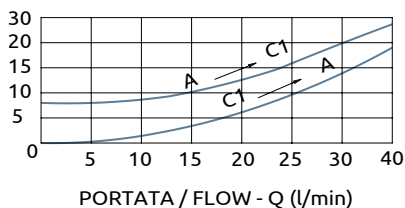

Corpo in acciaio / Steel body

A050353.03.00	110	38.5	34	38	94	8	35	50	32	8	Ø8.5
COD.	L	L1	L2	L3	L4	L5	S	H	H1	H2	D

DESCRIZIONE	DESCRIPTION
Permette il flusso libero da A verso C1 e da B verso C2, mentre nelle direzioni inverse il flusso è pilotato. Idonea al sostentamento di un carico, non al controllo discesa.	The valve allows free flow from A to C1 and from B to C2, whereas in the opposite directions the flow is piloted. Suitable to hold a load not to control a load lowering.



Codice Ordinazione	Rapporto di Pilotaggio	Portata Massima	Pressione Max	Incremento per Giro	Dimensione Porte	Peso
Ordering Code	Pilot Ratio	Max Flow	Max Pressure	Pressure Increase	Port Size	Weight
A050353.03.00	3.4:1	40 l/min	400 bar	8 bar	3/8"G	2.1 kg