

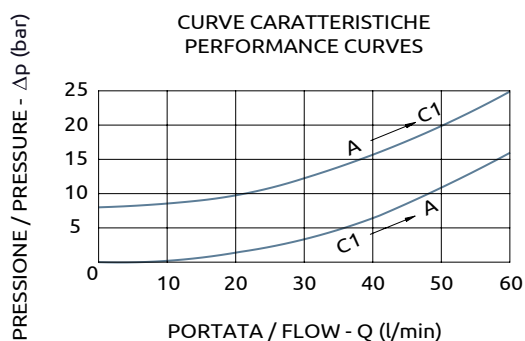

## Valvola di blocco doppia pilotata flangiabile Flangeable dual pilot operated check valve

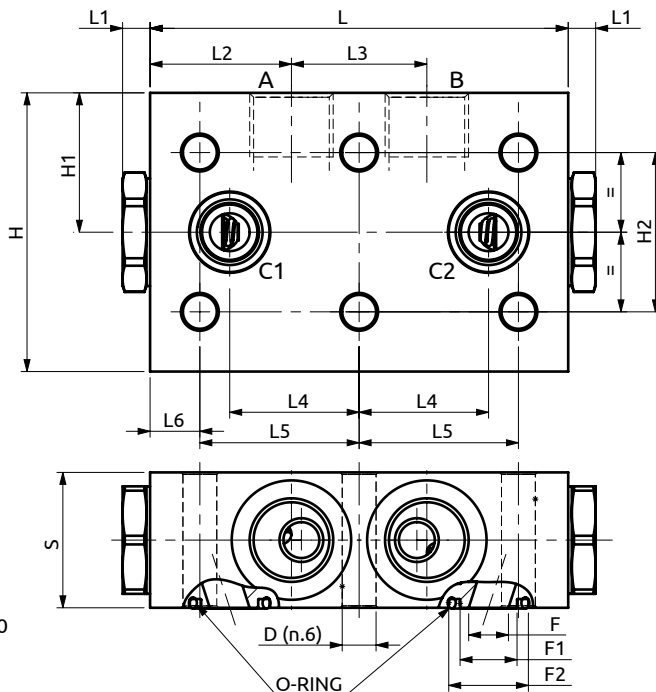
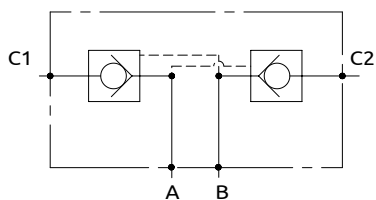

\* Corpo in alluminio / Aluminium body

105	7	35.5	34	32.5	40	12.5	34	70	35	40	Ø9.5	Ø14.3	Ø20.5	Ø8.5	O-RING 3062 Ø15.54x2.62
L	L1	L2	L3	L4	L5	L6	S	H	H1	H2	F	F1	F2	D	O-RING



## DESCRIZIONE

Permette il flusso libero da A verso C1 e da B verso C2. Idonea al sostentamento di un carico, non al controllo discesa.

## DESCRIPTION

The valve allows free flow from A to C1 and from B to C2. Suitable to hold a load not to control a load lowering.

Ordine	Ordine	Ordine	Ordine	Ordine	Ordine	Ordine
Code	Code	Code	Code	Code	Code	Code
Ordering Code	Pilot Ratio	Max Flow	Cracking Pressure	Max Pressure	Port Size	Weight
A050452.01.00	3.4:1	60 l/min	8 bar	400 bar	1/2"G	1.3 kg
A050452.02.00	7.1:1	60 l/min	8 bar	400 bar	1/2"G	1.3 kg
* B050452.01.00	3.4:1	60 l/min	8 bar	350 bar	1/2"G	0.7 kg
* B050452.02.00	7.1:1	60 l/min	8 bar	350 bar	1/2"G	0.7 kg
* B050452.03.00	5.2:1	60 l/min	8 bar	350 bar	1/2"G	0.7 kg