

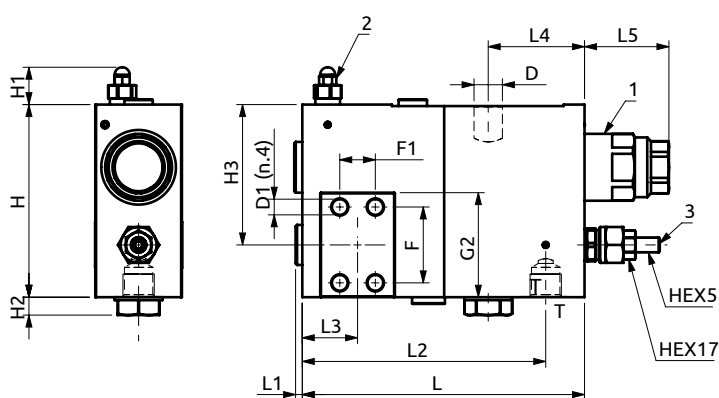

Valvola di blocco e controllo discesa
Load holding-metering valve for cranes

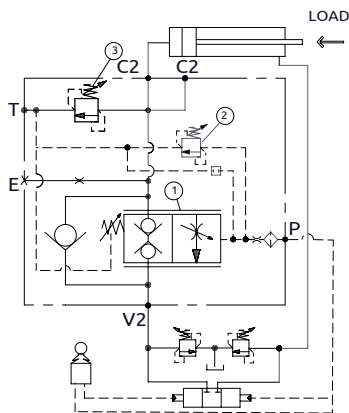

CURVE CARATTERISTICHE
PERFORMANCE CURVES

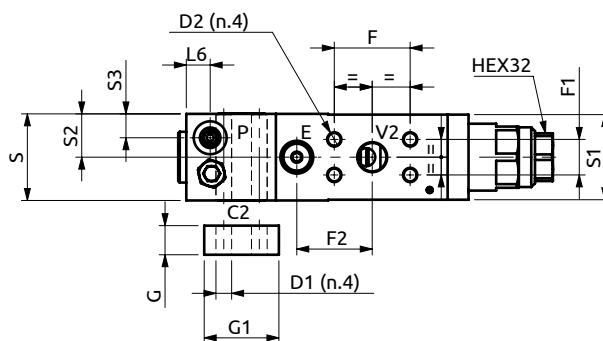
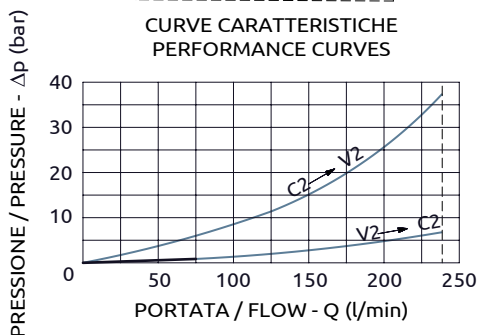

Corpo in acciaio / Steel body

189	4.5	124.5	37	64.5	56.5	16	58	57	29	16	129	25	12	94	50.8	23.8	50.5	19.5	50	70	Ø19	Ø10.5	M10
L	L1	L2	L3	L4	L5	L6	S	S1	S2	S3	H	H1	H2	H3	F	F1	F2	G	G1	G2	D	D1	D2



DESCRIZIONE

DESCRIPTION

Collegare all'impianto come da schema. Il pilotaggio della valvola è prelevato dai manipolatori di comando distributore e la valvola permette: il flusso libero da V2 verso C2, il sostentamento del carico con distributore in neutro o pompa ferma, controllo della discesa a valvola pilotata e protezione contro sovrappressioni nel cilindro. L'attacco T deve essere collegato direttamente a scarico.

To be connected as shown. The pilot signal is taken from the machine manipulators, the valve allows: free flow from V2 to C2, to hold the load with spool in neutral position or with the pump not running, controlled movement when pilot pressure is applied, relief function against overpressure in the cylinder. T port must be connected directly to the tank.

Codice Ordinazione	Campo di Taratura	Taratura Standard	Incremento per Giro	Portata Massima	Pressione Max	Dimensione Porte	Peso
Ordering Code	Pressure Range	Standard Setting	Pressure Increase	Max Flow	Max Pressure	Port Size	Weight
A068271.03.00	1 6-14 bar	9 bar	5 bar/turn	250 l/min	420 bar	V2-C2	10.7 kg
	2 15-30 bar	20 bar	3,2 bar/turn			E-P	
	3 100-350 bar	350 bar	110 bar/turn			T	