

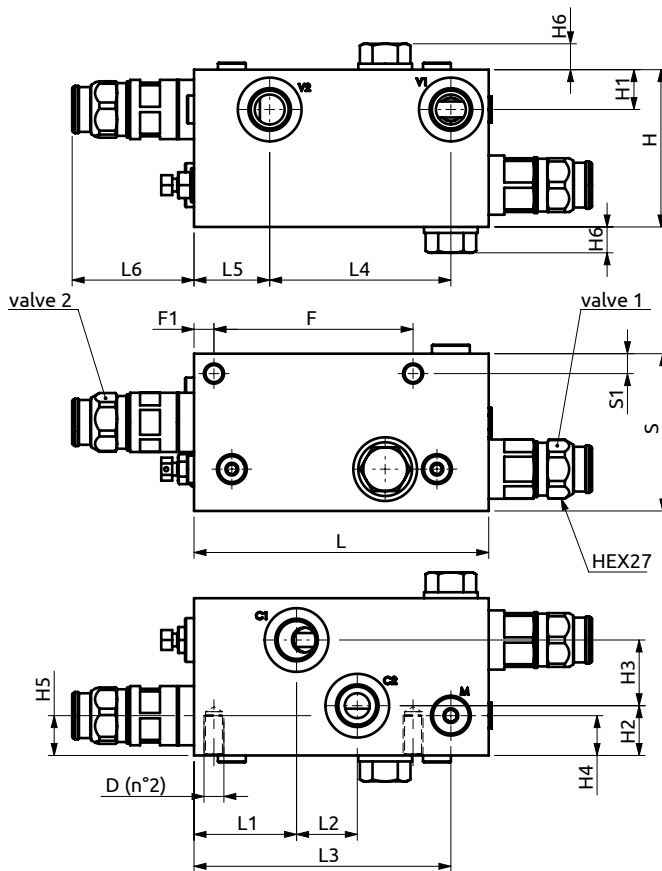

Valvola di blocco bilanciata doppia in linea con circuito rigenerativo serie 210
 Dual overcenter valve in line with regenerative circuit "210 series"

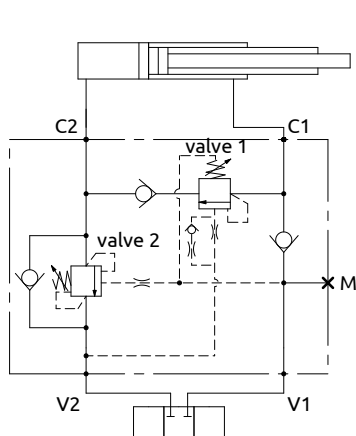

CURVE CARATTERISTICHE
 PERFORMANCE CURVES

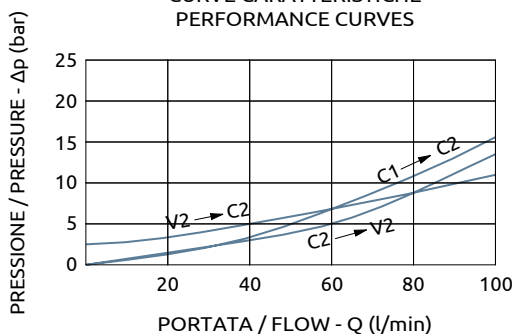

Corpo in alluminio / Aluminium body

B070460.05.00	148	51.5	30.5	129	91	38	61.2	79	10	79	20	25	33	20	22	13	100	10	M10
COD.	L	L1	L2	L3	L4	L5	L6	S	S1	H	H1	H2	H3	H4	H5	H6	F	F1	D



DESCRIZIONE	DESCRIPTION
La valvola oltre alle normali funzioni delle valvole di blocco permette di sommare l'olio scaricato dal lato stelo alla portata della pompa, permettendo di velocizzare l'uscita stelo. Durante lo sfilo la spinta del cilindro equivale alla sola pressione agente sulla sezione dello stelo.	The valve combines the normal functions of the overcenter valves with the regenerative function, adding the return flow from the rod side to the pump flow, to reduce the extension time. During the extension, the thrust of the cylinder matches only the pressure operating on the rod section.
CODICE ORDINAZIONE PIOMBATURA	SEALING ORDERING CODE

916013

Codice Ordinazione	Rapporto di Pilotaggio	Campo di Taratura		Taratura Standard	Incremento per Giro	Portata Massima	Pressione Max	Dimensione P	Peso	
Ordering Code	Pilot Ratio	Pressure Range		Standard Setting	Pressure Increase	Max Flow	Max Pressure	Port Size	Weight	
B070460.05.00	4:1	1	300-500 bar	420 bar	125 bar/turn	100 l/min	350 bar	V1, V2, C1, C2	1/2" G	3.2 kg
		2	300-500 bar	420 bar	125 bar/turn			M	1/4" G	