

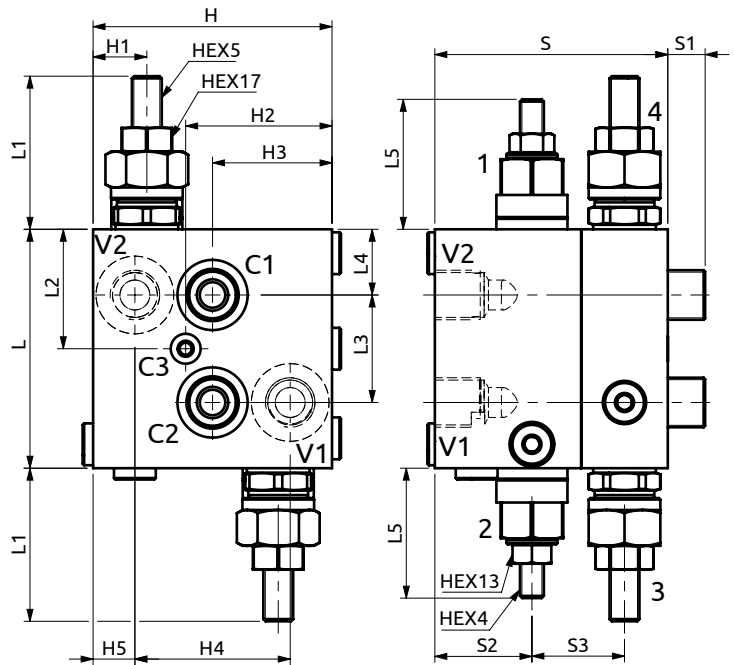

Valvola di blocco bilanciata doppia serie 165 flangiabile per motori idraulici
Dual overcenter valve "165 series" flangeable for hydraulic motors

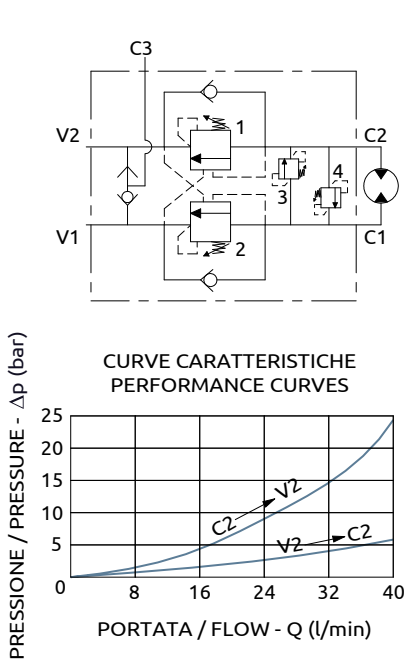

Corpo in alluminio / Aluminium body

80	~51.4	40	36	22	~43.5	78	12.5	32.5	31	80	18	49	40	52	14
L	L1	L2	L3	L4	L5	S	S1	S2	S3	H	H1	H2	H3	H4	H5



DESCRIZIONE

Valvola di blocco bilanciata doppia con flangiatura per motori idraulici DINAMICOIL.

DESCRIPTION

Dual flangeable overcenter valve for DINAMICOIL machines.

CODICE ORDINAZIONE
PIOMBATURASEALING ORDERING
CODE

916003 - 916005

Codice Ordinazione	Rapporto di Pilotaggio	Campo di Taratura		Taratura Standard	Incremento per giro	Portata Massima	Pressione Max	Dimensione Porte	Peso	
Ordering Code	Pilot Ratio	Pressure Range		Standard Setting	Pressure Increase	Max Flow	Max Pressure	Port Size	Weight	
B070381.22.00	4.2:1	1-2	60-220 bar	190 bar	135 bar/turn	40 l/min	350 bar	V1, V2, C1, C2	3/8"G	1.95 kg
		2-3	40-150 bar	90 bar	45 bar/turn			C3	1/4"G	